

Model 333 Single Channel USB Chromatography Data System Relay (Contact Closure) Installation

Remove the four screws holding the Model 333 A/D board in the stand-alone box.

If the 333 is installed in a GC or HPLC, remove the four hex head screws from the outside of the instrument which secure the 333 board to the inside of the chassis. This requires a 9/32" allen (hex) wrench.

The four mechanical single pole dual throw (SPDT) relays must be soldered into the board in the lower right hand corner of the 333 board. Each relay is rated at 24volts DC and 1 amp. For most handshaking applications where the relay is used to actuate a Valco valve for example there is very little current (often referred to as a contact closure).

You will need the following parts:

- Four SPDT relays
- Four 2N3904 transistors
- Four 10,000 ohm resistors
- Four 3position terminal blocks
- Four white wires
- Heat shrink tubing
- One red wire
- One black wire
- One 7812 voltage regulator
- One 10uf capacitor
- One .01uf capacitor

These parts are available as a kit from SRI under part# 8600-1051 \$207.00

(2022 pricing, prices subject to change, consult most recent price list.)

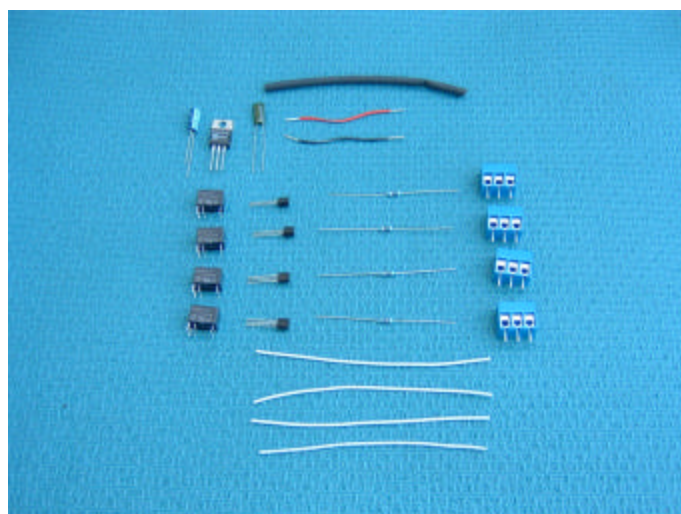
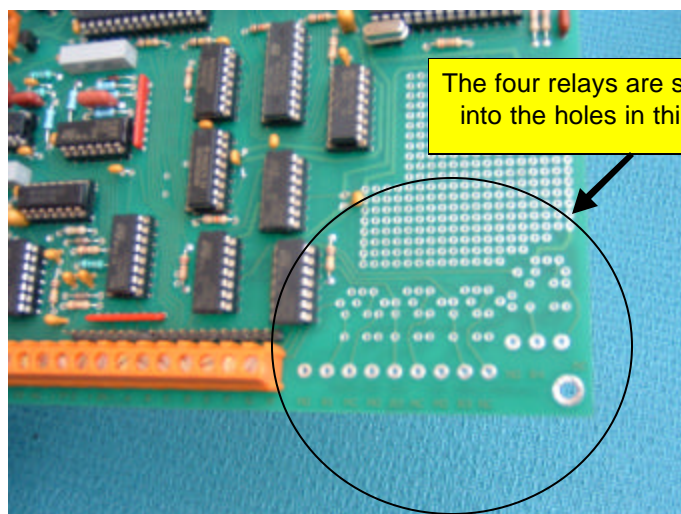
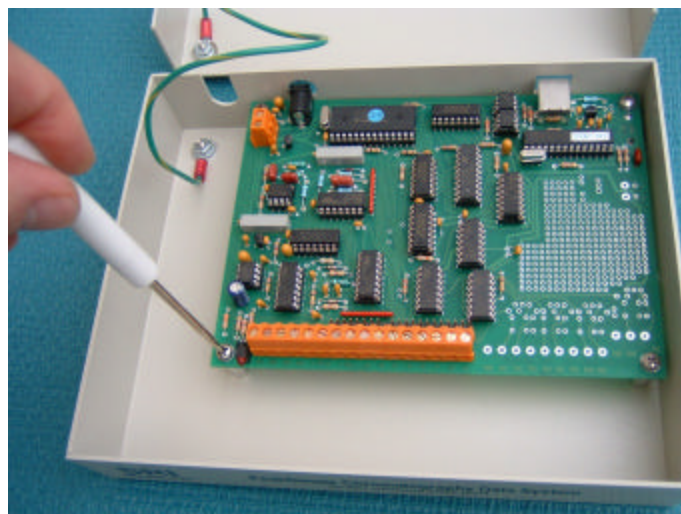

Model 333 Single Channel USB Chromatography Data System Relay (Contact Closure) Installation

You will need a soldering iron like the one shown to the right and solder.

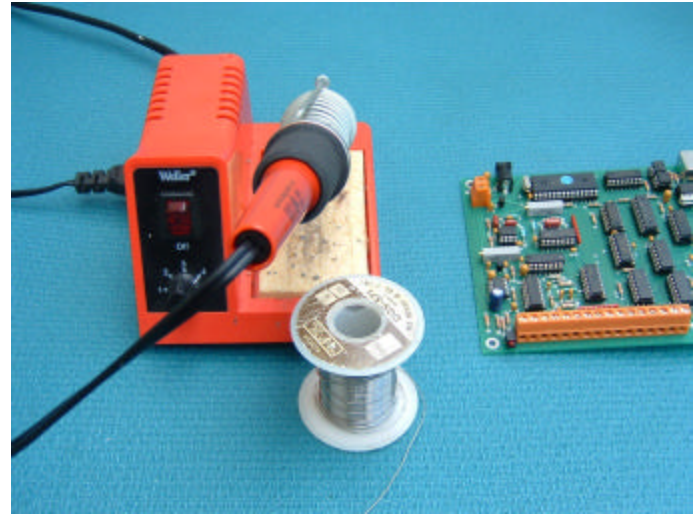

You will also need a small screwdriver, needle nose pliers, cutting pliers and wire stripper.



The parts are soldered in to the circuit board as shown in the drawing to the right.

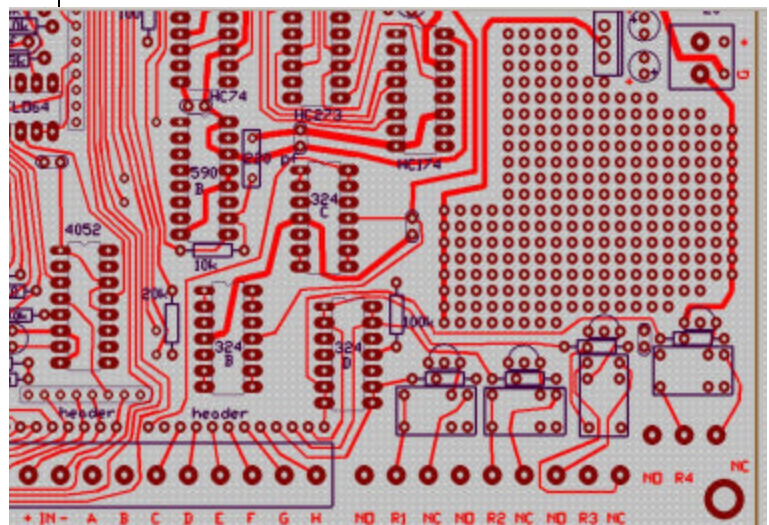

Model 333 Single Channel USB Chromatography Data System Relay (Contact Closure) Installation

Solder the 7812 volt-age regulator chip, the two capacitors and the red and black wires to the board as shown.

Be sure to install the 10uf electrolytic capacitor with the positive side facing the little + sign silkscreened on the board.

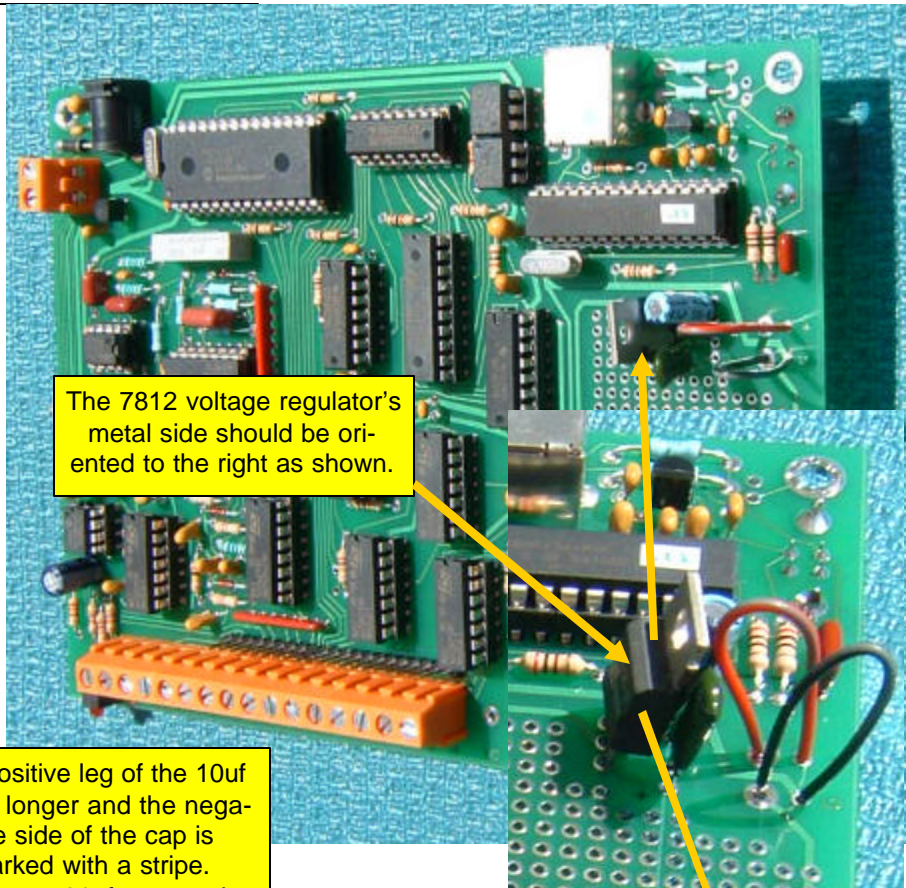

The 7812 voltage regulator's metal side should be oriented to the right as shown.

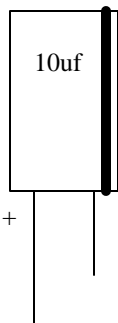

The positive leg of the 10uf cap is longer and the negative side of the cap is marked with a stripe. The green .01uf cap can be inserted either way, it is not polarity sensitive.

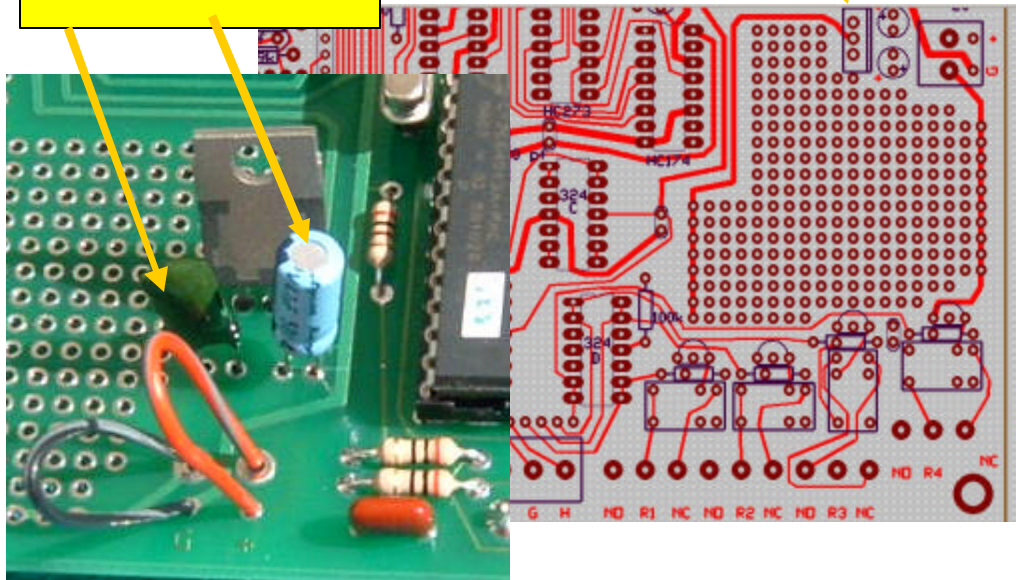

Model 333 Single Channel USB Chromatography Data System Relay (Contact Closure) Installation

Solder the white wire to the 10,000 ohm resistor by bending a little loop the resistor leg and another loop in the wires.

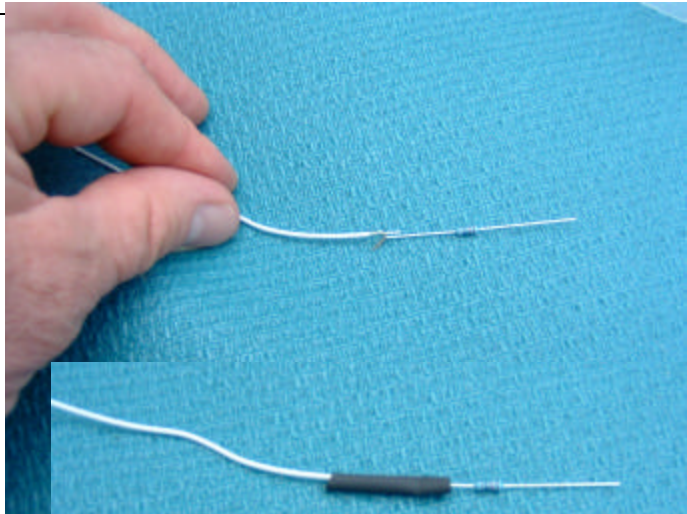

Place the heat shrink tubing over the soldered joint (after you solder it) and then use a heat gun or cigarette lighter to shrink the tubing down over the joint between the wire and the resistor to insulate it.

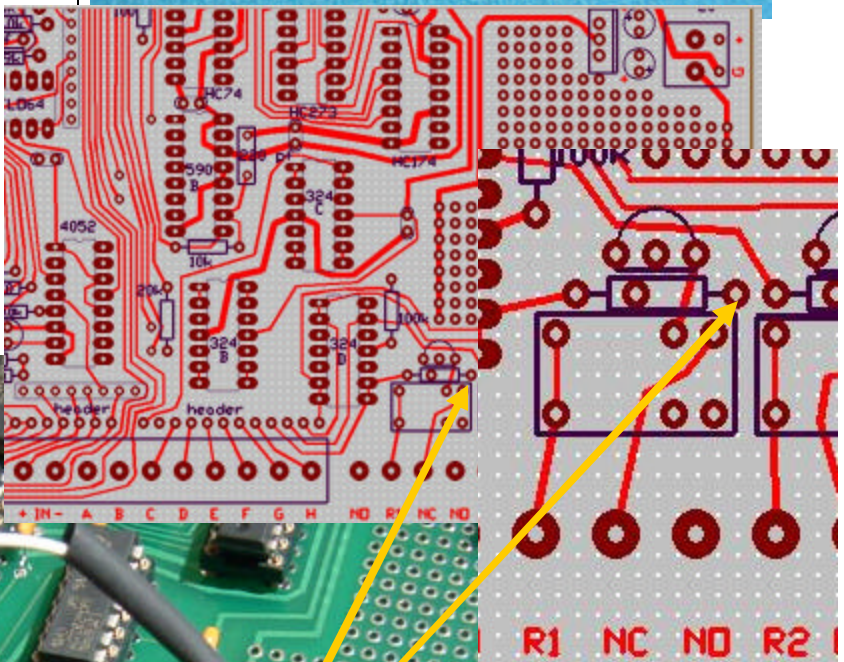

Solder the resistor to the board and then connect the other end of the wire (after you strip the insulation) to any one of the TTL output screw terminals (A,B,C,D E, F G or H). In the photo below the wire is connected to TTL output E.

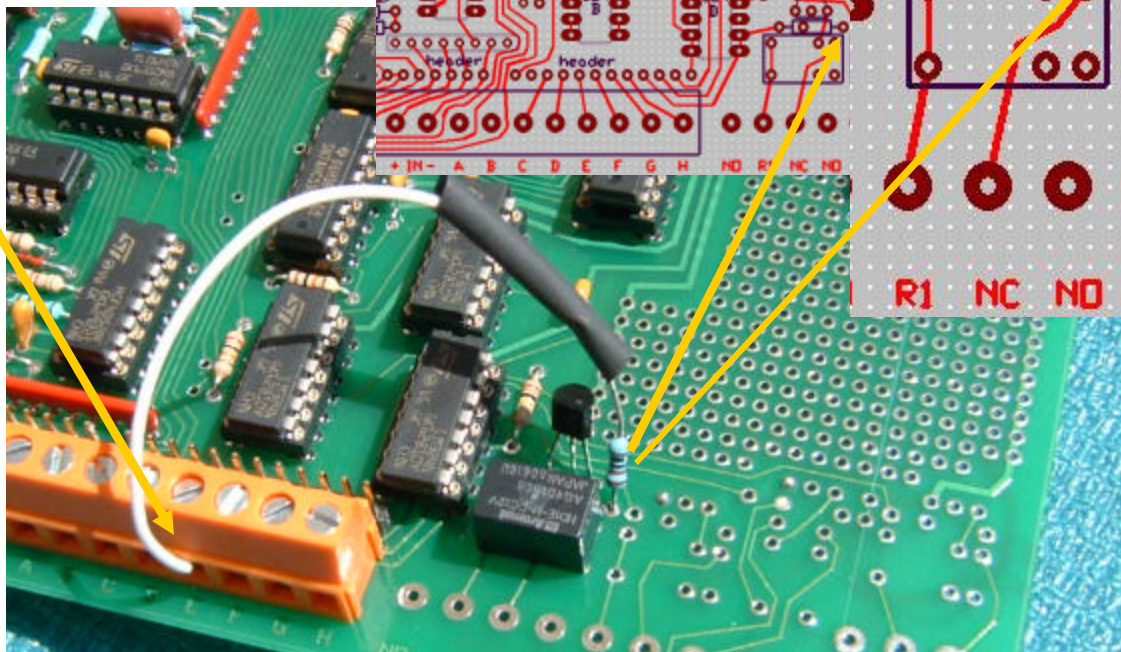

Model 333 Single Channel USB Chromatography Data System Relay (Contact Closure) Installation

Solder the 2N3904 transistor into the three holes provided for it. Note that the transistor has a flat side and a curved side.

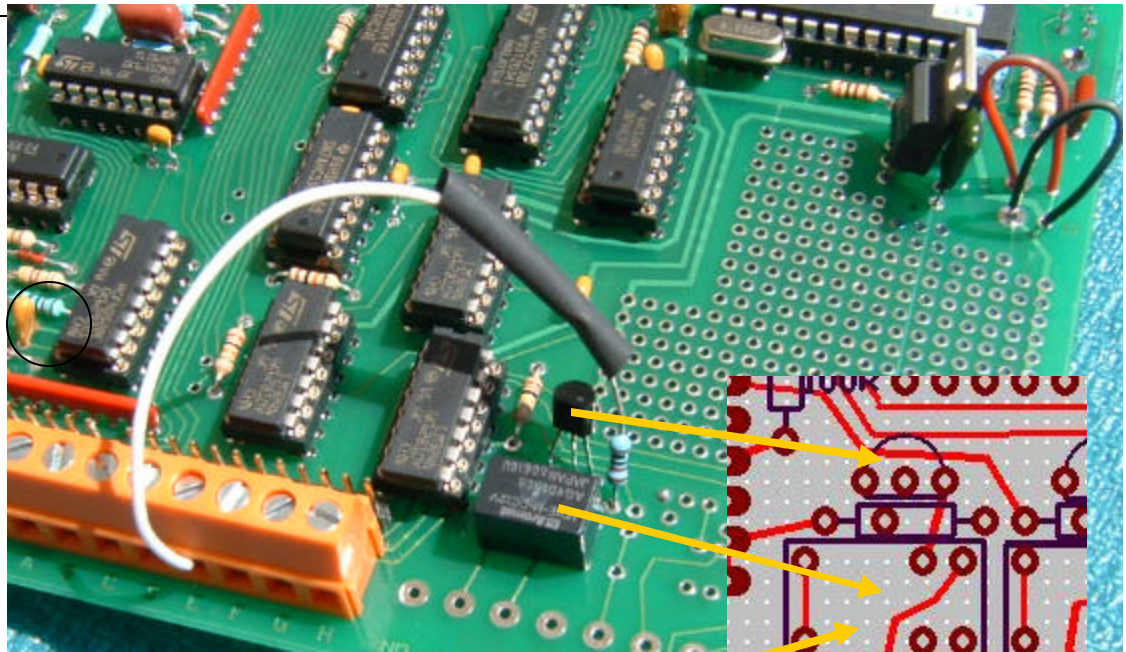

The flat side goes towards the bottom of the board as shown.

Then solder the SPDT relay into the 6 holes provided.

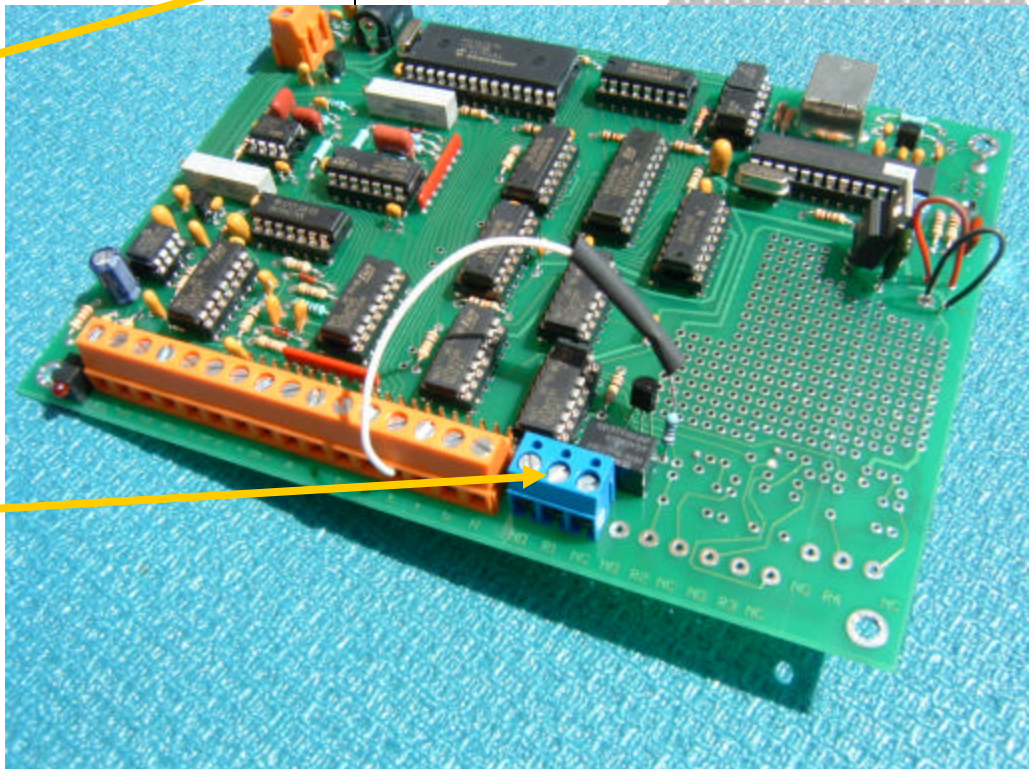

Finally, solder the 3 position terminal block into place.

Model 333 Single Channel USB Chromatography Data System Relay (Contact Closure) Installation

Repeat the installation process for Relays 2, 3, and 4.

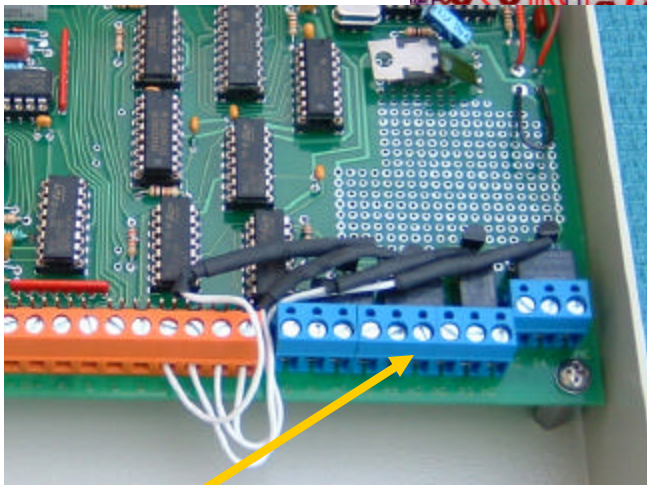
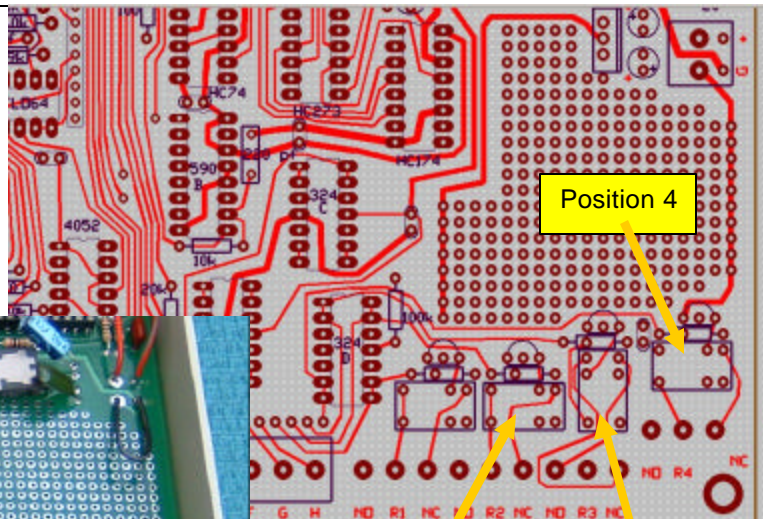

The 3 position terminal blocks have little interlocking ridges. Interlock the 3 terminal blocks for positions 1, 2 and 3 before inserting into the circuit board.

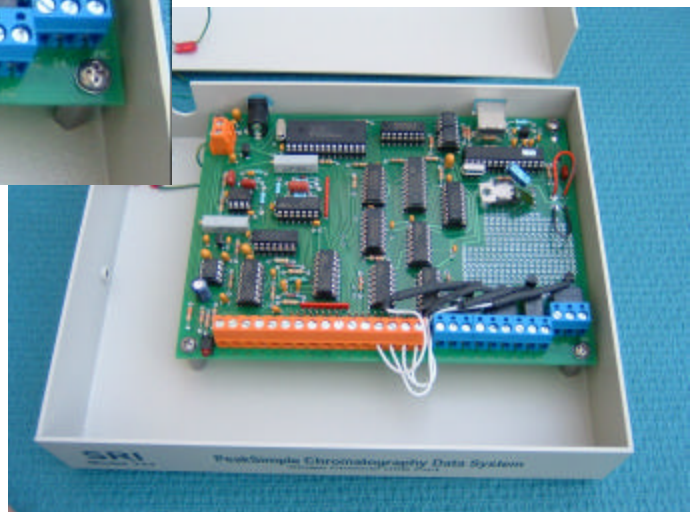

Secure the board back in the box or in the GC or HPLC to complete the installation .

Bend the 7812 voltage regulator over so it does not hit the top of the 333 box when the lid is attached

